

# wheeled travel bag

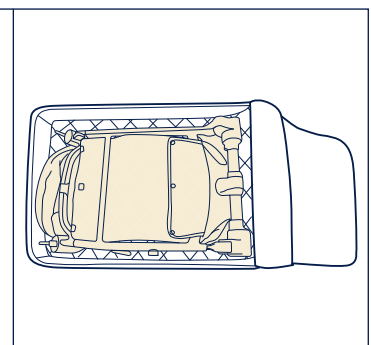

nuna®

*Designed  
around your life*

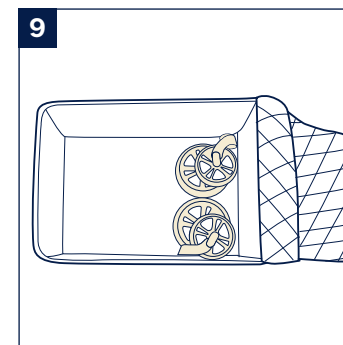
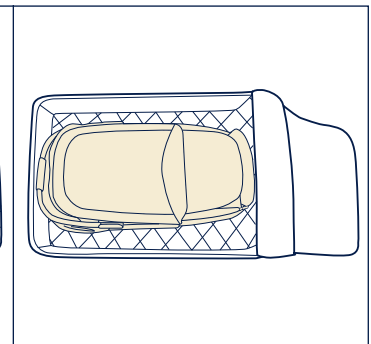
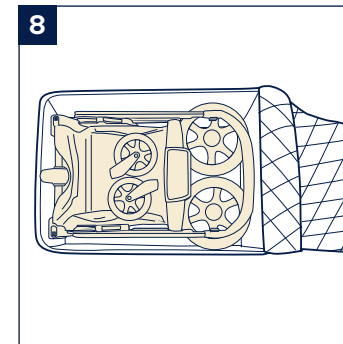
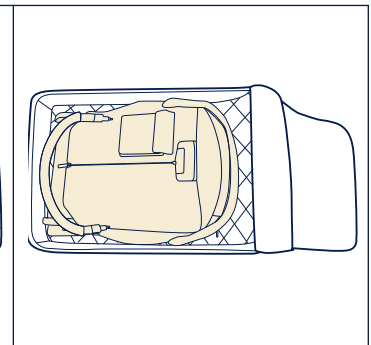
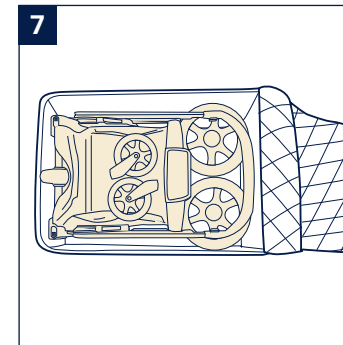
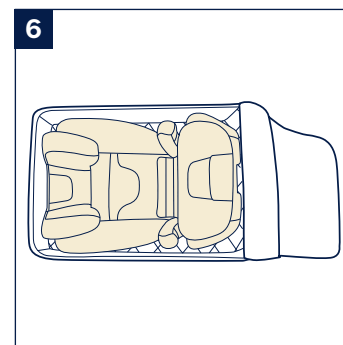
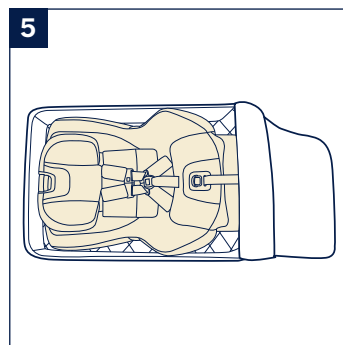
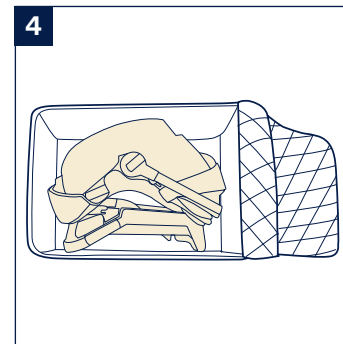
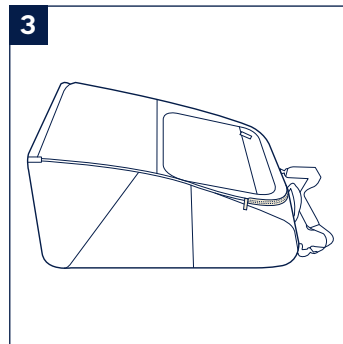
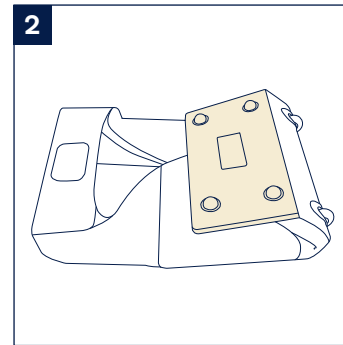
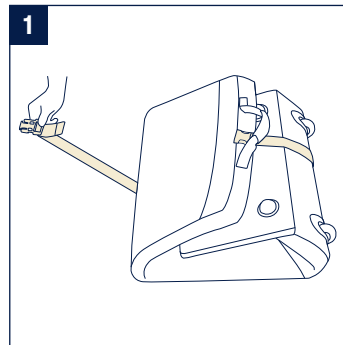

10

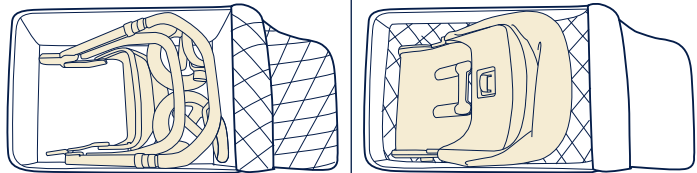

13

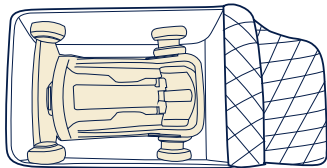

14

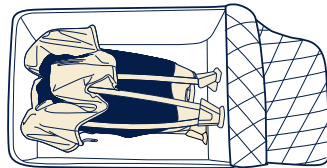

18

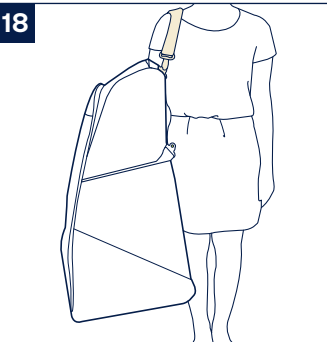

19

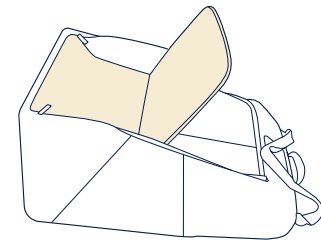

11

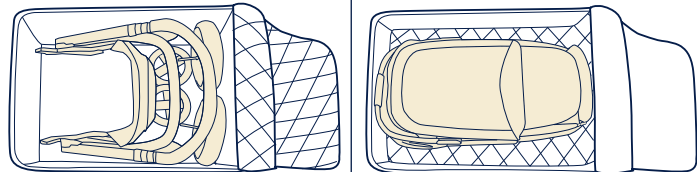

15

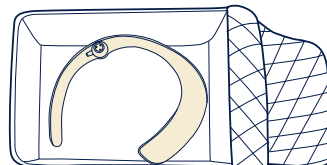

16

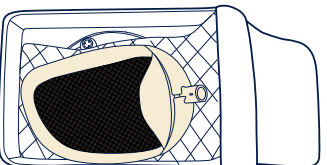

20

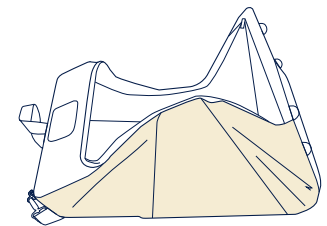

21

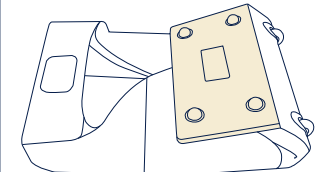

12

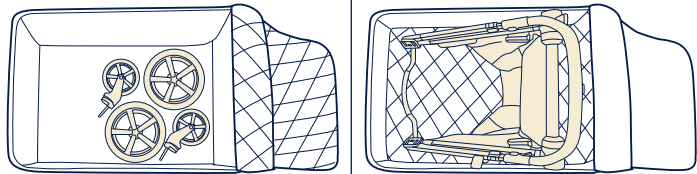

16

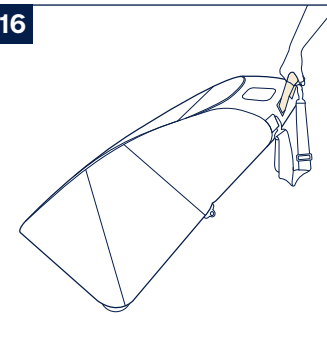

17

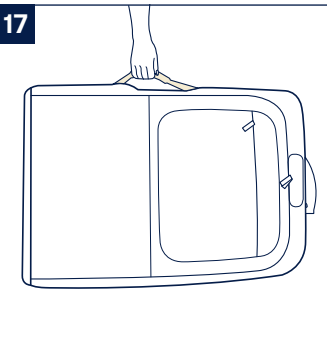

22

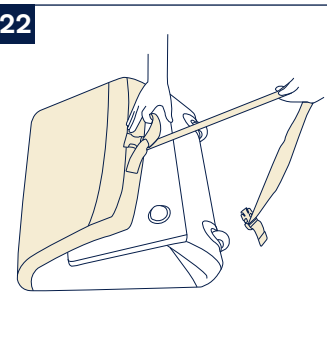

23

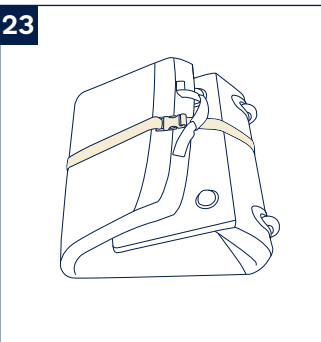

**IMPORTANT!**  
**KEEP THESE INSTRUCTIONS**  
**FOR FUTURE REFERENCE!**  
*READ CAREFULLY*

## Contents

Illustrations	1
Contact	8
Warnings	8
Product Use	9
Cleaning and Maintenance	9
Nederlands (NL)	10
Français (FR)	14
Deutsch (DE)	18
Italiano (IT)	22
Español (ES)	26

## Contact

For replacement parts, service, or additional questions, please contact our customer service department.

info@nuna.eu  
www.nuna.eu

### In the United Kingdom:

infouk@nuna.eu  
www.nuna.eu

### In the USA:

infousa@nuna.eu  
www.nuna.eu  
1.855.NUNA.USA

## WARNING

Failure to follow these warnings and instructions could result in serious injury or death.

A child's safety is your responsibility. **NEVER** leave your child unattended.

**DO NOT** use this product if it is damaged or broken.

**NEVER** allow children in this product.

## Product Use

This product can be used with:

- 1 - PIPA™ series + base
- 2 - RAVA™
- 3 - AACE™
- 4 - MIXX™ series frame and seat\*
- 5 - MIXX™ series frame and bassinet/carry cot
- 6 - TAVO™ series\*
- 7 - IVVI™ series frame and seat\*
- 8 - IVVI™ series frame and bassinet/carry cot
- 9 - DEMI™ grow frame\*
- 10 - PEPP™ series
- 11 - SENA™ mini series
- 12 - LEAF™ series

\*NOT including infant car seat

## Cleaning and Maintenance

Refer to the care label attached to the soft goods for washing and drying instructions.

It is normal for fabric to color from sunlight and to show wear and tear after a long period of use, even when used normally.

**BELANGRIJK!**  
**DEZE INSTRUCTIES BEWAREN**  
**VOOR LATER GEBRUIK.**  
*AANDACHTIG LEZEN*

## Inhoud

Abbildungen	1
Contact	12
Waarschuwingen	12
Gebruiken	13
Reiniging en onderhoud	13

## Contact

Neem contact op met onze klantenservice-afdelingen voor vervangende onderdelen, service of aanvullende vragen over de garantie.

info@nuna.eu  
www.nuna.eu

### In het Verenigd Koninkrijk:

infouk@nuna.eu  
www.nuna.eu

### In the USA:

infousa@nuna.eu  
www.nuna.eu  
1.855.NUNA.USA

## WAARSCHUWING

Niet-naleving van de waarschuwingen en de instructies kan ernstig letsel of de dood veroorzaken.

De veiligheid van uw kinderen is uw verantwoordelijkheid!

NOOIT uw kind zonder toezicht achterlaten.

Dit product niet gebruiken als er beschadigde of ontbrekende onderdelen zijn.

Kinderen nooit toestaan om in het product.

## Gebruiken

Dit product kan worden gebruikt

- 1 - PIPA™ series + base
- 2 - RAVA™
- 3 - AACE™
- 4 - MIXX™ series frame and seat\*
- 5 - MIXX™ series frame and bassinet/carry cot
- 6 - TAVO™ series\*
- 7 - IVVI™ series frame and seat\*
- 8 - IVVI™ series frame and bassinet/carry cot
- 9 - DEMI™ grow frame\*
- 10 - PEPP™ series
- 11 - SENA™ mini series
- 12 - LEAF™ series

\*NIET inclusief kinderstoel

## Reiniging en onderhoud

Raadpleeg de verzorgingslabels die aan de zachte goederen zijn bevestigd voor was- en drooginstructies.

Het is normaal dat materialen verkleuren door blootstelling aan zonlicht en na langdurig gebruik slijtage vertonen, zelfs bij gangbaar gebruik.

**IMPORTANT !  
CONSERVEZ CES  
INSTRUCTIONS POUR UNE  
UTILISATION FUTURE !**  
*LIRE ATTENTIVEMENT*

## Sommaire

Illustrations	1
Contact	16
Avertissements	16
Utilisation du produit	17
Nettoyage et maintenance	17



## Contact

Pour des informations sur les pièces de rechange, le service ou des questions supplémentaires sur la garantie, veuillez contacter notre service client.

info@nuna.eu  
www.nuna.eu

### Au Royaume-Uni :

infouk@nuna.eu  
www.nuna.eu

### In the USA:

infousa@nuna.eu  
www.nuna.eu  
1.855.NUNA.USA

## AVERTISSEMENT

**Ne pas suivre ces avertissements et instructions peut conduire à de sérieuses blessures ou la mort.**

La sécurité de votre enfant est votre responsabilité.

**NE LAISSEZ JAMAIS** votre enfant sans surveillance.

N'utilisez Pas ce produit si des pièces sont endommagées ou manquantes.

Ne laissez Jamais votre enfant dans le produit.

## Gebruiken

Ce produit est destiné pour

- 1 - PIPA™ series + base
- 2 - RAVA™
- 3 - AACE™
- 4 - MIXX™ series frame and seat\*
- 5 - MIXX™ series frame and bassinet/carry cot
- 6 - TAVO™ series\*
- 7 - IVVI™ series frame and seat\*
- 8 - IVVI™ series frame and bassinet/carry cot
- 9 - DEMI™ grow frame\*
- 10 - PEPP™ series
- 11 - SENA™ mini series
- 12 - LEAF™ series

\*N'inclut pas le siège d'auto pour bébé

## Nettoyage et maintenance

Consultez les étiquettes d'entretien attachée aux pièces souples pour obtenir les instructions de lavage et de séchage.

La coloration du tissu exposé au soleil est normale, tout comme les signes d'usure et de déchirement après une longue période d'utilisation, même normale.

**WICHTIG!**  
**BEWAHREN SIE DIESE**  
**ANWEISUNGEN ZUM**  
**KÜNFTIGEN NACHSCHLAGEN**  
**AUF!**  
*SORGFÄLTIG LESEN*

## Inhalt

Illustrations	1
Kontakt	20
Warnhinweise	20
Produkt verwenden	21
Reinigung und Wartung	21

## Kontakt

Wenden Sie sich für Ersatzteile, Service und weitere Garantiefragen an unseren Kundendienst.

info@nuna.eu  
www.nuna.eu

### Vereinigtes Königreich:

infouk@nuna.eu  
www.nuna.eu

### In the USA:

infousa@nuna.eu  
www.nuna.eu  
1.855.NUNA.USA

DE

## WARNHINWEISE

Nichtbeachtung dieser Warnungen und Anweisungen könnte zu schweren Verletzungen oder zum Tode führen.

Die Sicherheit des Kindes liegt in Ihrer Verantwortung.

Lassen Sie Ihr Kind niemals unbeaufsichtigt.

Dieses Produkt Nicht verwenden, wenn Teile davon beschädigt sind oder fehlen.

Kindern niemals erlauben in im Produkt.

## Gebriiken

Dieses Produkt kann mit genutzt werden

- 1 - PIPA™ series + base
- 2 - RAVA™
- 3 - AACE™
- 4 - MIXX™ series frame and seat\*
- 5 - MIXX™ series frame and bassinet/carry cot
- 6 - TAVO™ series\*
- 7 - IVVI™ series frame and seat\*
- 8 - IVVI™ series frame and bassinet/carry cot
- 9 - DEMI™ grow frame\*
- 10 - PEPP™ series
- 11 - SENA™ mini series
- 12 - LEAF™ series

\*NICHT inklusive Kindersitz

## Reinigung und Wartung

Beachten Sie beim Reinigen und Trocknen die Pflegeetiketten an den Textilteilen.

Es ist selbst bei gewöhnlichem Gebrauch normal, dass Textilien nach langer Benutzung durch Sonnenlicht verblassen und Verschleißerscheinungen aufweisen.

DE

**IMPORTANTE!**  
**CONSERVARE PER FUTURE**  
**CONSULTAZIONI!**  
*LEGGERE ATTENTAMENTE*

## Indice

Illustrazioni	1
Recapito	24
Avvertenze	24
Uso del prodotto	25
Pulizia e manutenzione	25

## Recapito

Per la sostituzione di parti, manutenzione o domande sulla garanzia, contattare il dipartimento di assistenza al cliente.

info@nuna.eu  
www.nuna.eu

### Nel Regno Unito:

infouk@nuna.eu  
www.nuna.eu

### In the USA:

infousa@nuna.eu  
www.nuna.eu  
1.855.NUNA.USA

## AVVERTENZA

La mancata osservanza delle seguenti avvertenze e istruzioni potrebbe causare lesioni gravi o decesso.

La sicurezza dei bambini è vostra responsabilità.

NON lasciare mai il bambino incustodito.

NON utilizzare questo prodotto se presenta danni o parti mancanti.

Non consentire ai bambini di dentro al prodotto.

## Gebruiken

Questo prodotto può essere utilizzato con

- 1 - PIPA™ series + base
- 2 - RAVA™
- 3 - AACE™
- 4 - MIXX™ series frame and seat\*
- 5 - MIXX™ series frame and bassinet/carry cot
- 6 - TAVO™ series\*
- 7 - IVVI™ series frame and seat\*
- 8 - IVVI™ series frame and bassinet/carry cot
- 9 - DEMI™ grow frame\*
- 10 - PEPP™ series
- 11 - SENA™ mini series
- 12 - LEAF™ series

\*NON includere il seggiolino per bambini

## Pulizia e manutenzione

Fare riferimento alle etichette sui rivestimenti imbottiti per le istruzioni di lavaggio e asciugatura.

È normale che i tessuti si scoloriscano per effetto della luce solare e che presentino tracce di usura dopo un lungo periodo d'uso, anche se utilizzati in modo normale.

**¡¡IMPORTANTE!  
¡GUARDE ESTAS  
INSTRUCCIONES PARA  
FUTURAS CONSULTAS!  
LÉALAS DETENIDAMENTE**

## Índice

Ilustraciones	1
Contacto	28
Advertencias	28
Uso del producto	29
Limpieza y mantenimiento	29

## Contacto

Para obtener información sobre piezas de repuesto y servicio técnico, o para resolver dudas acerca de la garantía adicional, póngase en contacto con nuestro departamento de atención al cliente.

info@nuna.eu  
www.nuna.eu

### En el Reino Unido:

infouk@nuna.eu  
www.nuna.eu

### In the USA:

infousa@nuna.eu  
www.nuna.eu  
1.855.NUNA.USA

## ⚠️ ADVERTENCIA

Si no sigue las advertencias e instrucciones que se exponen a continuación, podría provocar graves lesiones o, incluso, la muerte.

La seguridad del niño es su responsabilidad.

NUNCA deje al niño desatendido.

NO utilice este producto si está dañado o si falta alguna de sus piezas.

NUNCA deje que los niños se queden en el producto.

## Gebruiken

Este producto se puede utilizar con

- 1 - PIPA™ series + base
- 2 - RAVA™
- 3 - AACE™
- 4 - MIXX™ series frame and seat\*
- 5 - MIXX™ series frame and bassinet/carry cot
- 6 - TAVO™ series\*
- 7 - IVVI™ series frame and seat\*
- 8 - IVVI™ series frame and bassinet/carry cot
- 9 - DEMI™ grow frame\*
- 10 - PEPP™ series
- 11 - SENA™ mini series
- 12 - LEAF™ series

\*NO incluye el asiento infantil para automóvil

## Limpieza y mantenimiento

Consulte las etiquetas de cuidados cosidas al acolchado para conocer las instrucciones de lavado y secado.

Es normal que la tela se decolore debido a la luz del sol, y se desgaste y se rompa después de un largo periodo de uso, incluso si se utiliza de una forma normal.







The Nuna logo is a stylized, lowercase 'nuna' in a light beige color. The letters are rounded and connected, with a registered trademark symbol (®) to the upper right of the 'a'.

nuna®

*Find out more at [nuna.eu](http://nuna.eu)*